



COMMERCIAL DOOR INSTALLATION INSTRUCTIONS SERIES 1000

CAUTION

Use proper lifting equipment and correct lifting procedures to avoid damage or injury.

WARNING!

A rolling door is a large heavy object that moves with the help of springs under extreme tension. Moving objects and springs under tension can cause serious injuries or death. For your safety and the safety of others, follow these instructions.

PUSH-UP OPERATION SHOWN

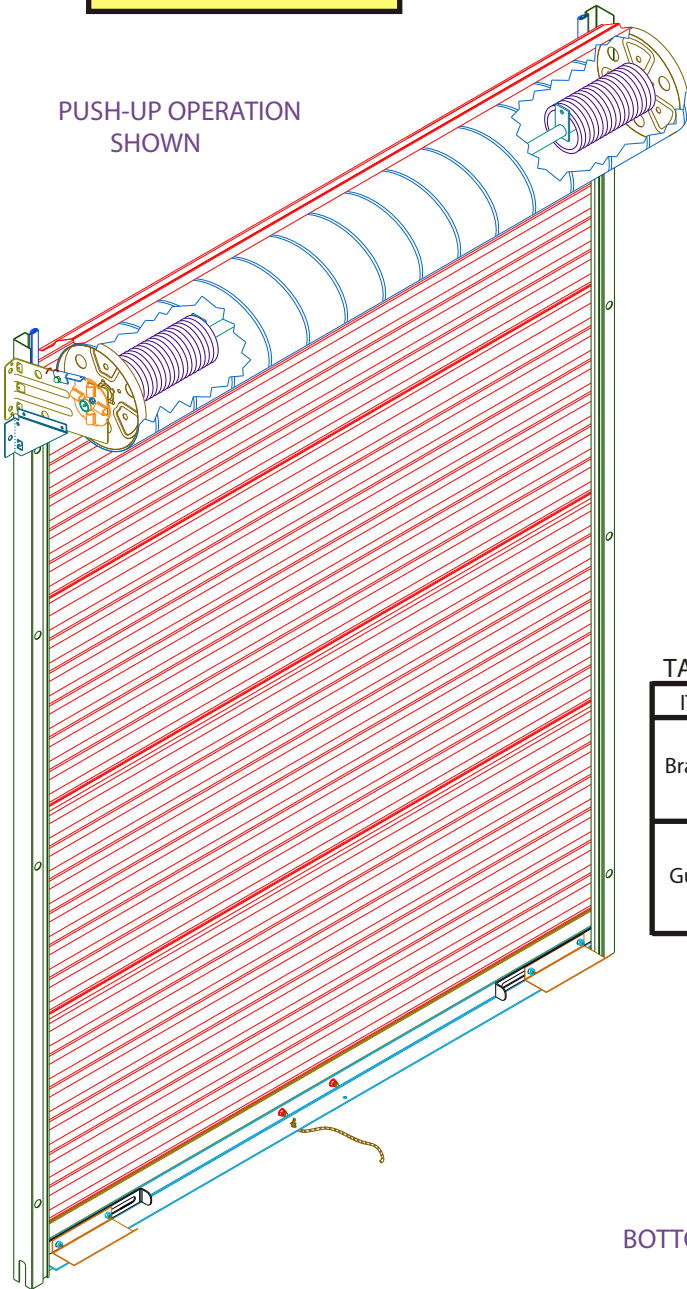



POTENTIAL HAZARD	EFFECT	PREVENTION
 MOVING DOOR	CAN CAUSE SERIOUS INJURY OR DEATH	DO NOT stand or walk under moving door. Keep door in full view and free of obstructions while operating. DO NOT allow children to operate the door.
 EXTREME SPRING TENSION	CAN CAUSE SERIOUS INJURY OR DEATH	Installation, repairs and adjustments must be made by a trained rolling service door systems technician using proper tools and instructions. DOOR MUST BE FULLY OPENED WHEN MAKING ADJUSTMENTS.
 ELECTRIC SHOCK	CAN CAUSE SERIOUS BURNS OR DEATH	Turn off electrical power before removing operator cover. Operator must be electrically grounded.

TABLE 1: Wall Fasteners - for jamb attachment of Brackets and Guides

ITEM	JAMB	FASTENERS	DRILL SIZE
Brackets	Steel	1/4-14 x 1" TEKS Screw	None
	Concrete or Filled Block	3/8" x 1-3/4" Powers Wedge-Bolt	Powers 01316
	Wood	3/8-7 x 3" Lag Screw	None
Guides	Steel	1/4-14 x 1" TEKS Screw	None
	Concrete or Filled Block	1/4" x 1-3/4" Powers Wedge-Bolt	Powers 01314
	Wood	1/4-10 x 1" Lag Screw	None

BOTTOM BAR ASSEMBLY
FIGURE 1

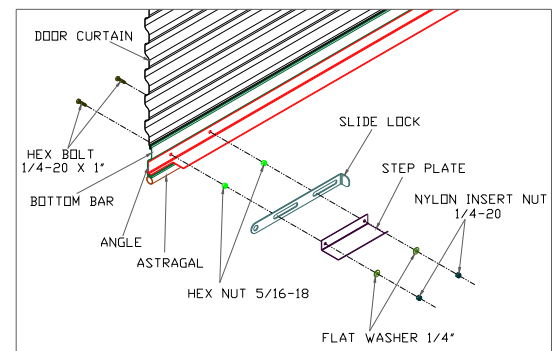

IMPORTANT NOTE: Do not cut tape and plastic wrap that holds the door in a roll until you are directed to do so in step 6B. Janus International Corporation cannot guarantee or accept responsibility for doors that are not installed as directed. Please read and understand all instructions before beginning the installation process

SIDE ROOM REQUIRED *

GUIDE	OUTSIDE OF EACH BRACKET LEG	EACH END OF AXLE	OUTSIDE OF CHAIN DRIVE
2-1/2"	3-11/16"	3-1/2"	5-1/2"

* Dimensions are taken from edge of opening

CLEARANCE CHARTS

FIGURE 2

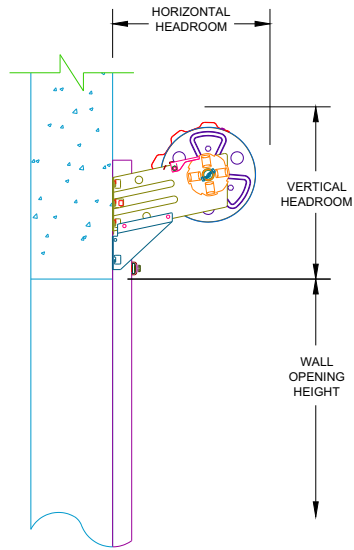
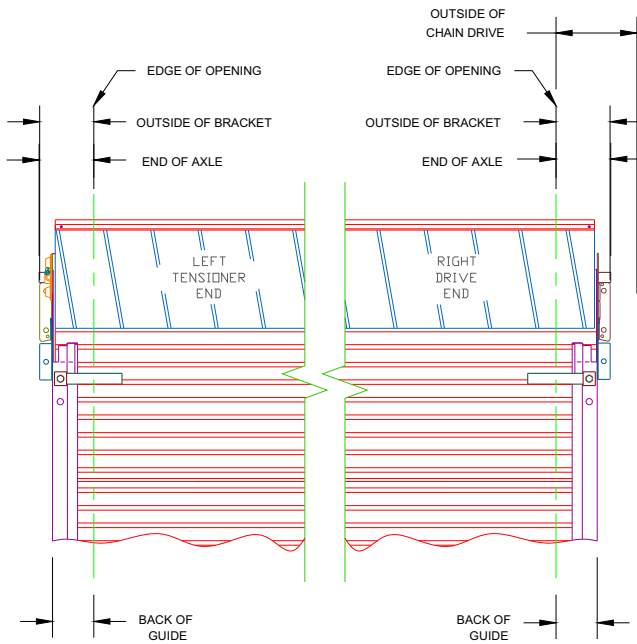

HEADROOM REQUIRED

OPENING HEIGHT	VERTICAL HEADROOM	HORIZONTAL HEADROOM
THRU 8'-0"	18"	17-1/2"
OVER 8'-0" THRU 10'-0"	18-1/2"	17-3/4"
OVER 10'-0" THRU 12'-0"	18-3/4"	18"
OVER 12'-0" THRU 14'-0"	19"	18-1/2"

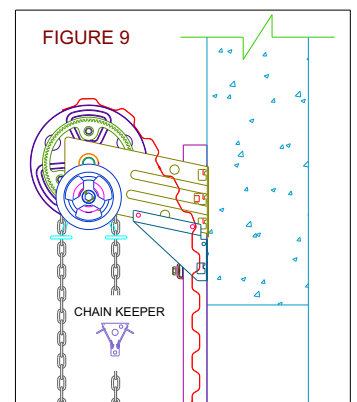
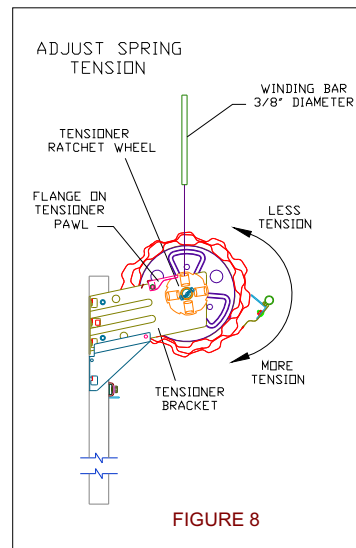
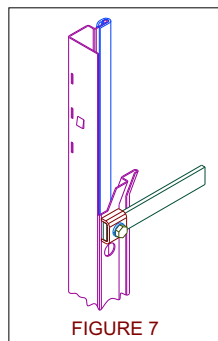
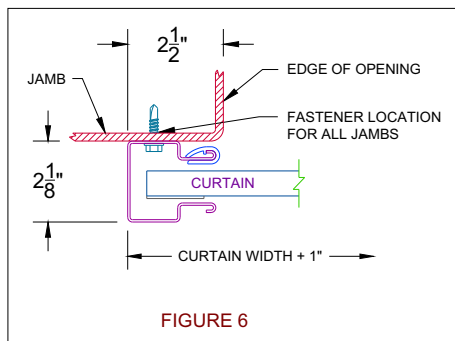
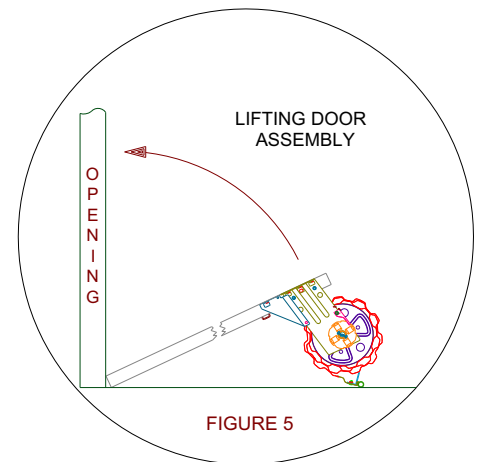
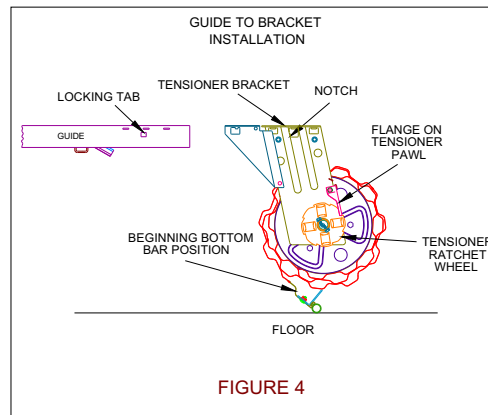
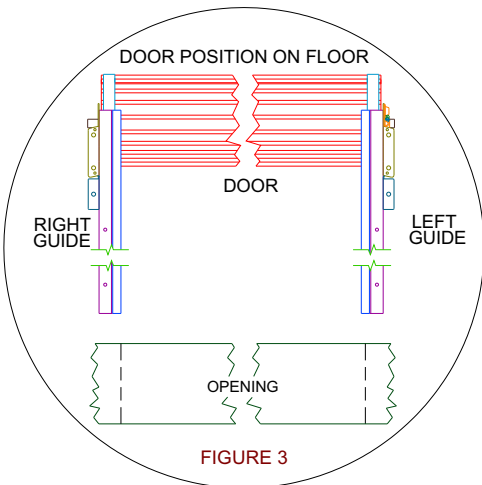

STEP 1: WALL OPENING

- A. Check wall opening width and height and verify these measurements against size of door to be installed.
- B. Verify that jambs are plumb.
- C. Check floor and header for level.
- D. Check for adequate side clearance at jambs and clearance above and at sides of header. See clearance charts figure 2 for minimum requirements.
- E. Verify that the guide mounting surface on the jamb is flush.
- F. Make sure all parts required for installation are with the door.

STEP 2: POSITION DOOR AND PARTS

- A. Make sure floor is clean in order to prevent damage to curtain.
- B. On inside of building, place left guide on floor perpendicular to opening with guide bottom close to the left jamb and the top toward inside of building. Do the same with the right guide to the right jamb. See figure 3.
- C. Place door on floor positioned at top of and between guides. Rotate door as necessary to locate bottom bar against floor. See figures 3 and 4.
- D. Distribute hardware parts to appropriate areas.

NOTE: Brackets, tensioner, spring(s) and chain hoist (when required) are pre-assembled to the door at the factory. Do not remove.

STEP 3: GUIDES TO BRACKETS INSTALLATION

- A. At tensioner end of door, lift flange on tensioner pawl until end of the pawl clears the tensioner ratchet wheel. Rotate bracket in order to position short leg end upward. Release flange on pawl and allow end to engage with the nearest tooth on the ratchet wheel. See figure 4.
- B. Bring top end of guide in alignment with bracket and insert hooks on bracket into slots in guide.
- C. Slide bracket and guide together until locking tab in guide fully engages notch in bracket.
- D. If locking tab does not fully engage with bracket notch, use a hammer and punch to bend tab into bracket notch.
- E. Repeat steps 3B through 3D for other bracket and guide. This bracket will require being held in position.

⚠ WARNING!
Locking tab in guide must fully engage with notch in bracket. Failure to do so may allow the door to fall during installation, which can cause serious injury or death and/or damage to door.

STEP 4: GUIDES AND BRACKETS TO JAMB

- A. Brackets and guides will be attached to jambs using fasteners shown in table 1.
- B. The guides should be mounted centered about the opening and spaced curtain width + 1" apart. This spacing is measured from back of guide to back of guide. See figure 6. Both guides must be plumb.
- C. The appropriate fastener must be installed at each hole location in brackets and guides. See table 1.

⚠ WARNING!
Door can fall if both brackets are not securely fastened to the jambs. All fasteners attaching brackets to jambs must fit securely into a structural member or surface. If door falls, serious injury or death and/or damage to door can result.

STEP 5: LIFTING DOOR ASSEMBLY

- A. Move door and guide assemblies toward wall opening with bottom of guides resting next to jambs.
- B. Lift door assembly evenly, pivoting around bottom of guides. See figure 5.
- C. If a forklift is used, forks must be padded in order to prevent damage to curtain.
- D. Attach brackets and guides to jambs, according to step 4.
- E. Chain pocket wheel may be removed and chain guide rotated for access to bracket fasteners.

⚠ WARNING!

Two installers are required to lift door assembly into position against jambs. The guides are not designed to support the curtain weight during a one man installation. Attempting to make installation with only one installer can result in serious injury and/or damage to door. Do not leave door unattended until it is securely attached to jambs.

NOTE: Welding of guides to the jambs is not recommended.

STEP 6: REDUCED HAND CHAIN DRIVE

- A. Feed hand chain over chain pocket wheel and through chain guide. Connect ends of hand chain, being careful not to twist chain. Hand chain may be lengthened or shortened as necessary. See Figure 9.
- B. Align chain guide and tighten setscrew.
- C. Install hand chain keeper on wall or jamb.

STEP 7: SETTING SPRING INITIAL TENSION

⚠ WARNING!

Extreme spring tension can cause serious injury or death. Installation, repairs and adjustments must be made by a trained rolling service door systems technician using proper tools and instructions. Door must be fully opened when making adjustments.

- A. Rotate door 1-1/2 revolutions in the direction that would send the bottom bar down through the guides.
- B. While firmly holding the door at the bottom bar, cut the tape and plastic wrap that holds the door in a coil. Direct the bottom bar down into the guides, stopping just past the head stop area.

STEP 8: HEAD STOPS

Slide head stop into holder from inside of each guide. Secure with 3/8-16 x 1/2" hex bolt and 3/8" lock washer. See figure 7.

STEP 9: SLIDE LOCK, STEP PLATE AND PULL ROPE

- A. Lower bottom bar and install slide lock and step plate using 2 each 1/4-20 x 1" hex bolts, 5/16-18 hex nuts, 1/4" flat washers and 1/4-20 nylon insert hex nuts. Do this at both ends of the bottom bar. See figure 1.
- B. Transfer the 1/4-20 x 1/2" carriage bolts and 1/4-20 serrated flange hex nuts that were removed from both ends of the bottom bar to the 2 holes at the center of bottom bar and angle.
- C. For push-up operation only, install rope in one of the holes at the center of the horizontal leg of the bottom bar angle.

STEP 10: CHECK DOOR OPERATION

- A. Lower and raise the door to test the door balance.
- B. If door is easy to close, but hard to open; increase spring tension.
- C. If door is hard to close, but easy to open; decrease spring tension.

STEP 11: ADJUST SPRING TENSION

⚠ WARNING!

DOOR MUST BE FULLY OPENED WHEN MAKING ADJUSTMENTS.

- A. Place 3/8" diameter winding bar in tensioner ratchet wheel. See figure 8.
- B. Rotate winding bar in the down direction to increase spring tension. Each engagement of a tooth equals 1/8 turn.
- C. To decrease spring tension, pull down slightly on winding bar until pawl disengages tooth. Lift flange on pawl and move winding bar up until past the pawl/tooth engagement. Allow pawl to rest on ratchet wheel and continue moving winding bar up until the pawl is fully engaged with the tooth.
- D. Remove winding bar and operate door.
- E. Repeat steps 10A through 10D as necessary.